



**CONCEPTUAL PRESENTATION
PROPOSED IT PARK
VANGANI, AMBERNATH TALUKA**

**PRELIMINARY CONCEPT DESIGN
PRESENTATION**

Design Development

credibility



Case study :
DLF CYBERCITY, GURUGRAM



Design Development



THE BLUEPRINT FOR MODERN CORPORATE URBANISM

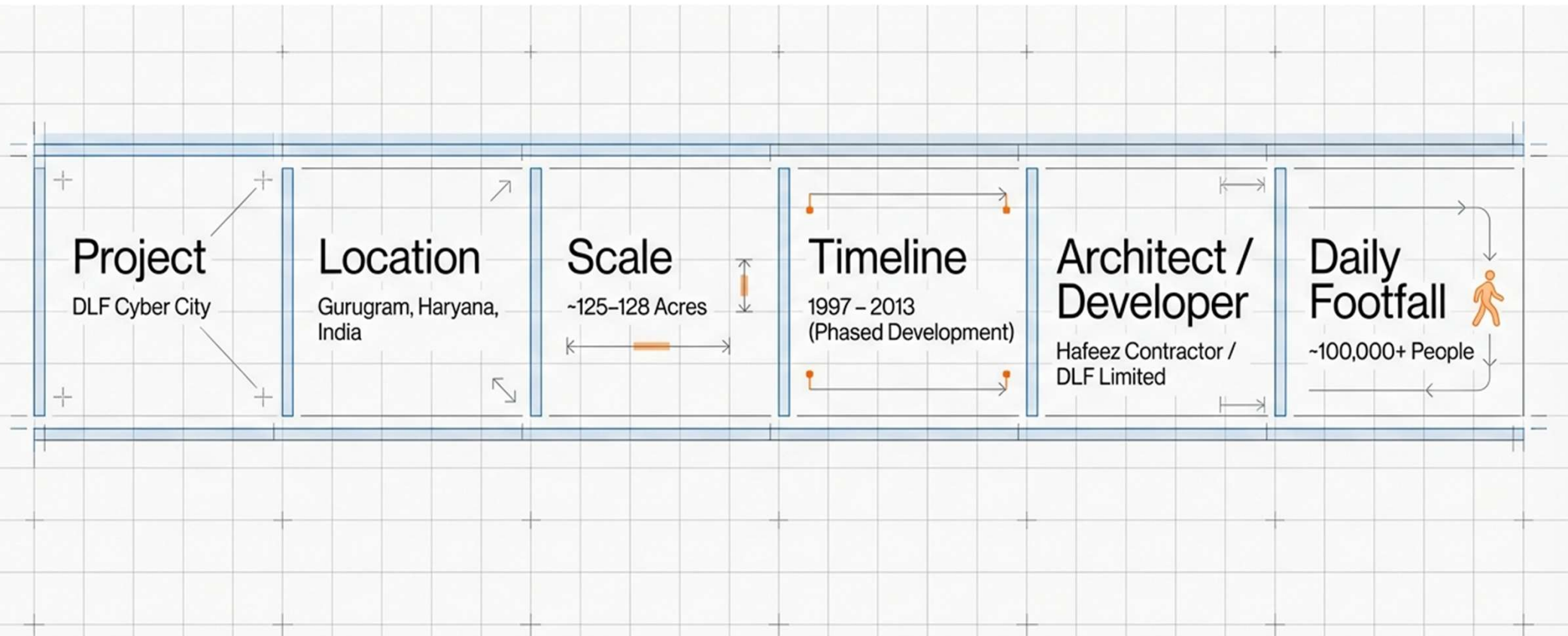

Design Development



MASTER LAYOUT

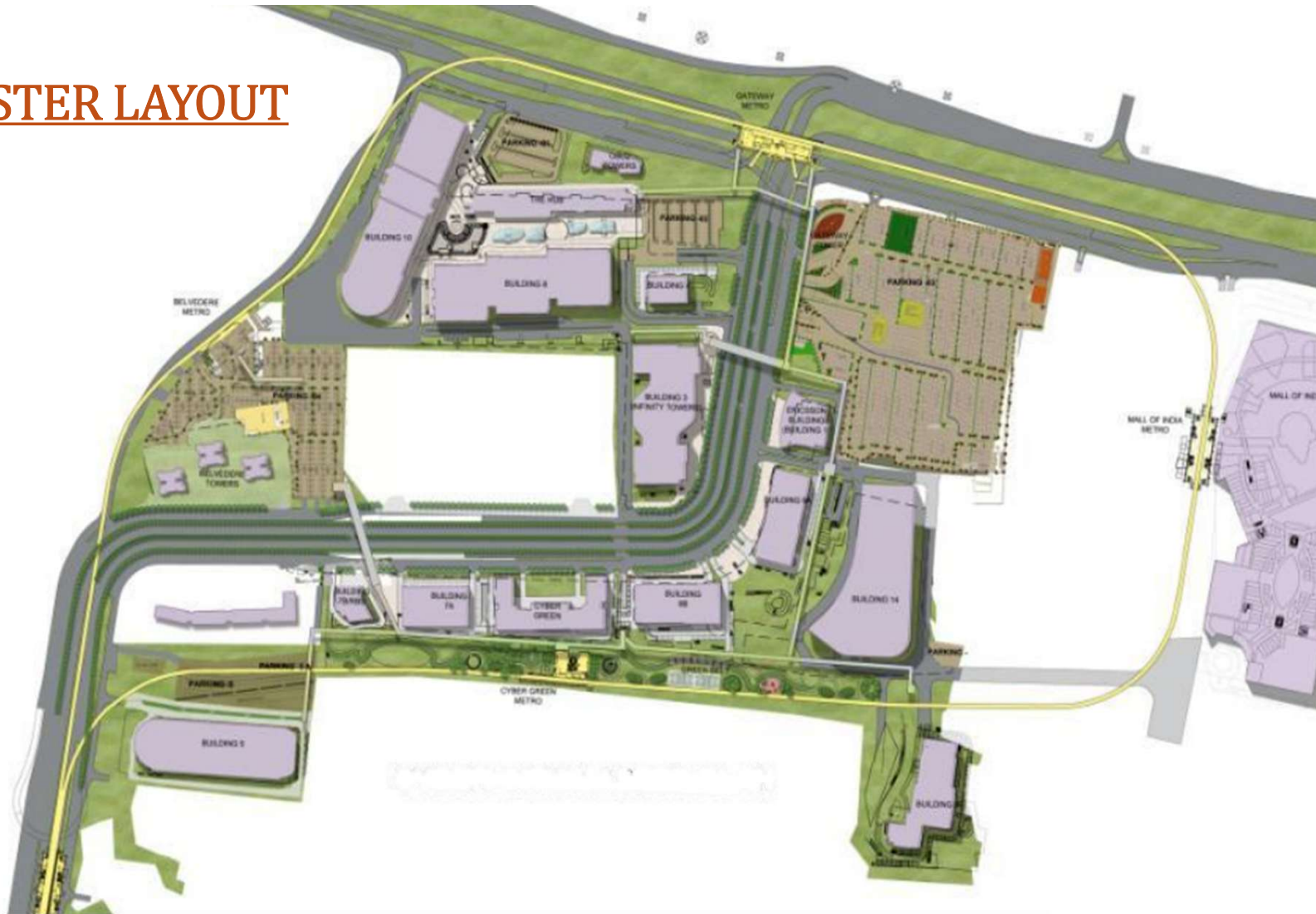

Design Development



DEFINING THE URBAN CORPORATE AESTHETIC

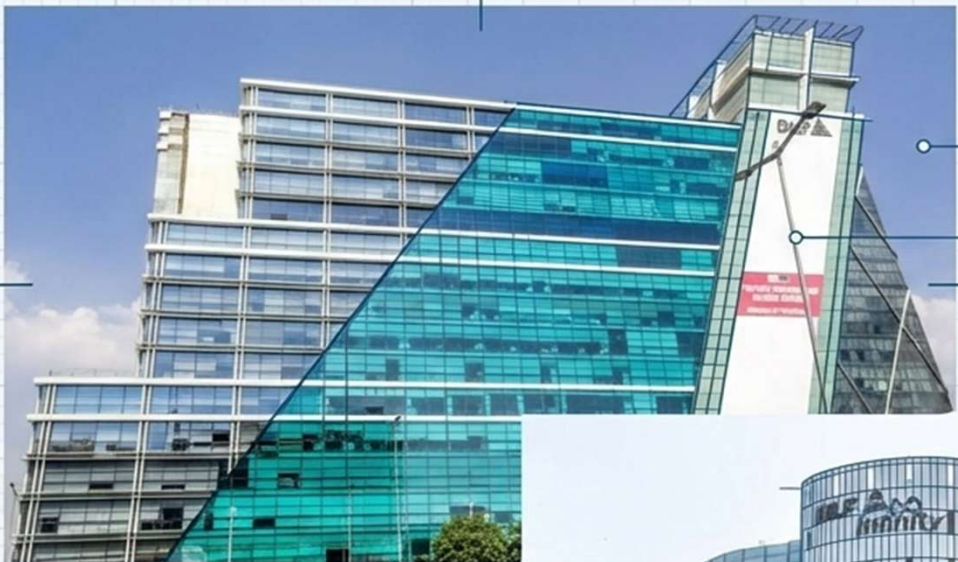

MATERIALITY
Glass façade high-rises (10–20+ floors) utilizing steel and RCC composite structures.

DESIGN LANGUAGE
Contemporary international style defined by clean vertical lines and expansive curtain wall glazing.

SPATIAL ORGANIZATION
Floorplates prioritize open office planning with central cores (lifts, central HVAC, services) to maximize flexible interiors for global MNCs.

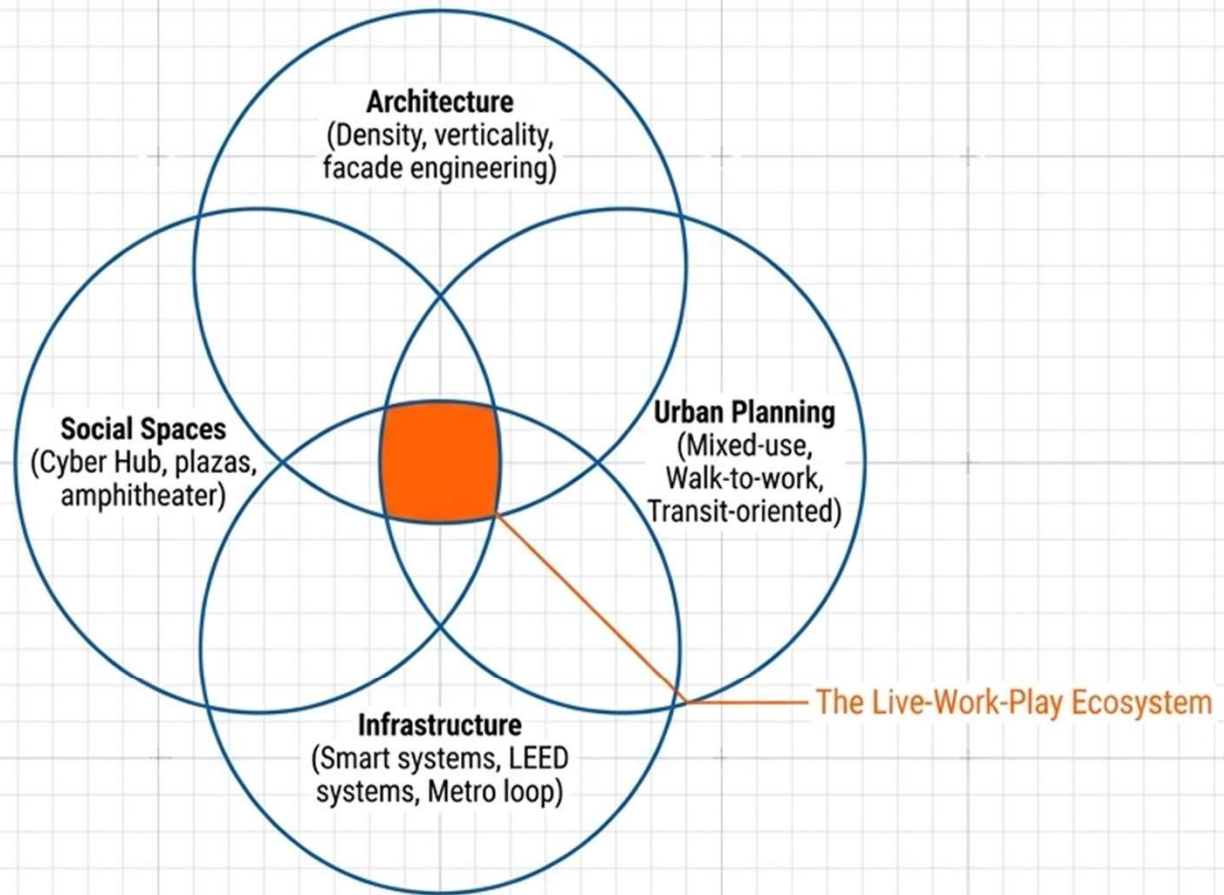

DLF Cyber City transcends the definition of an IT park. By balancing density with livability, and corporate efficiency with public realm vibrancy, it establishes the benchmark prototype for future business districts.

DLF CYBERCITY, GURUGRAM

- DLF Cyber City is a commercial area opened in 2003.
- The area has been termed a "futuristic commercial hub" and is considered one of the largest hubs of this activity in Delhi NCR.
- Cyber city lies near Udyog Vihar, which is a conventional industrial area on the opposite side of NH-48.
- Cyber city Gurugram, an integrated business district spanning 125 acres, offers approximately 15 million sq.Ft. Of commercial spaces for retail and corporate operations.
- In 2013, the rapid metro was introduced to Cyber City, connecting it with the Delhi Metro. Six operational stations are within the cyber city.
- The NH-48 runs through Cyber City, and a 16-lane expressway also runs internally. A flyover between Cyber City and MG Road was opened in 2015 to reduce traffic congestion.
- The Indira Gandhi International Airport is located close to the cyber city.

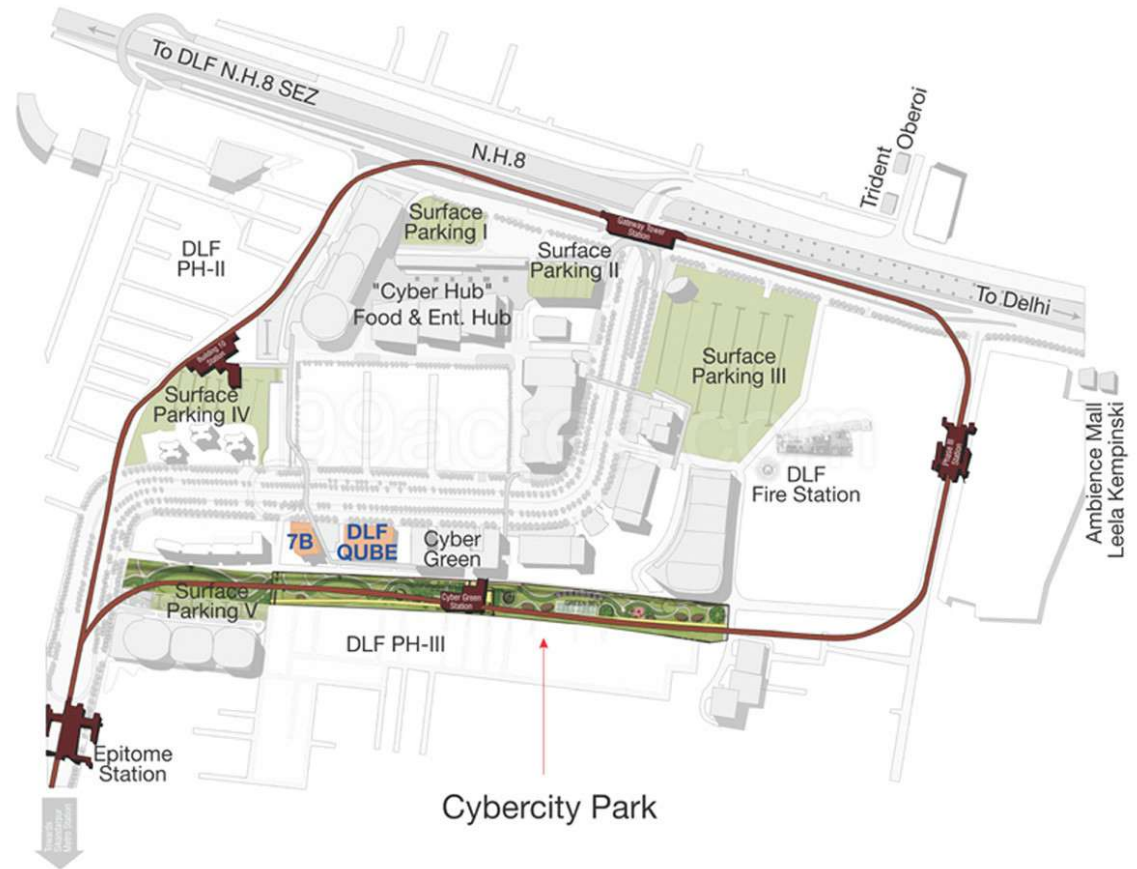

DLF GATEWAY TOWER

FLOORS = 12

AREA = 85000SQFT

- Gateway tower, as its name suggests, acts as the gateway to the 3000-acre landmark city of DLF.
- This 12-story complex is spread across an area of 1.15 acres. With its ship-like shape, the gateway tower presents futuristic architecture, which is also reflected in its interiors with floor plates measuring 85,000 sq. ft. FT equipped with MERV-14 filters and LEED Platinum USGBC certifications.

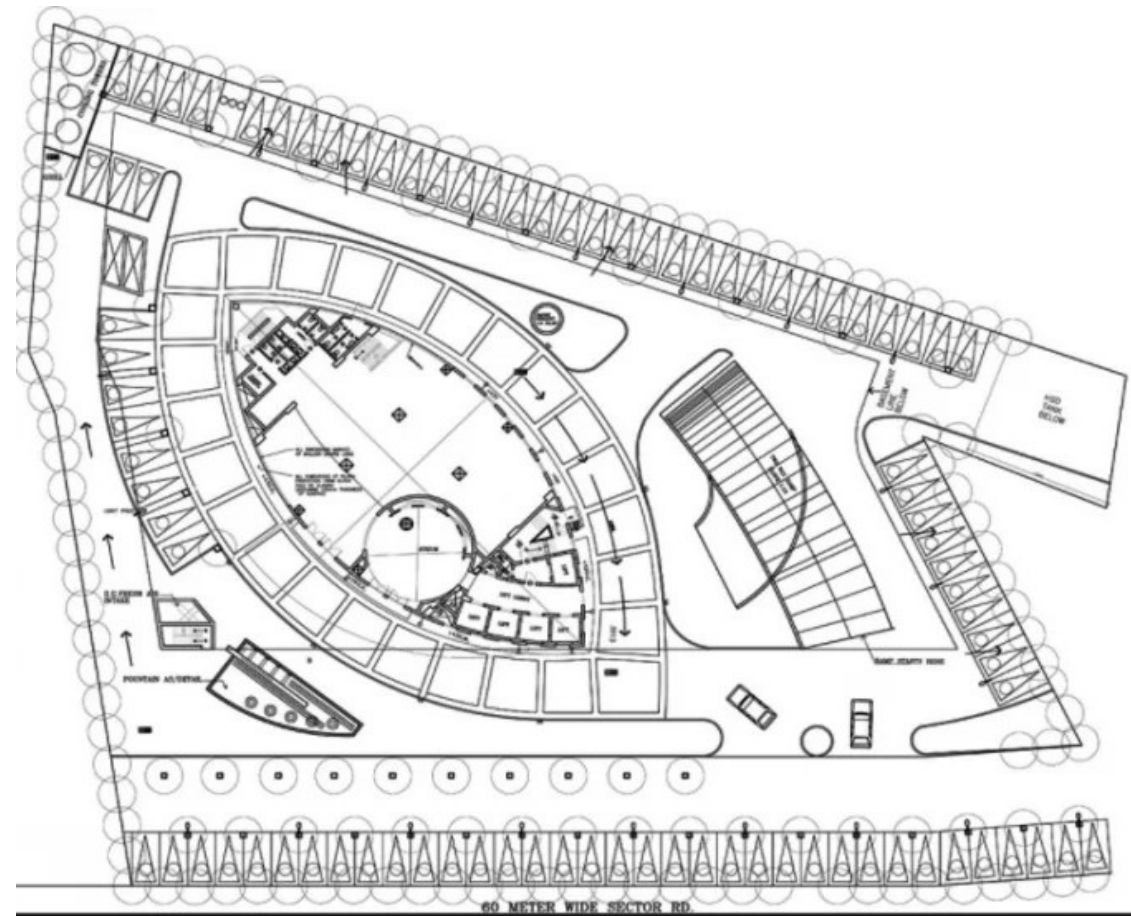

Design Development



ERICSSON FORUM

- Ericsson forum represents the company's Indian corporate office and consolidates its multiple offices in the national capital region.
- Located in Cyber City with an area of 3.90 acres.
- The complex has been designed to Ericsson's international specifications, conforming to the futuristic designs and world-class features.

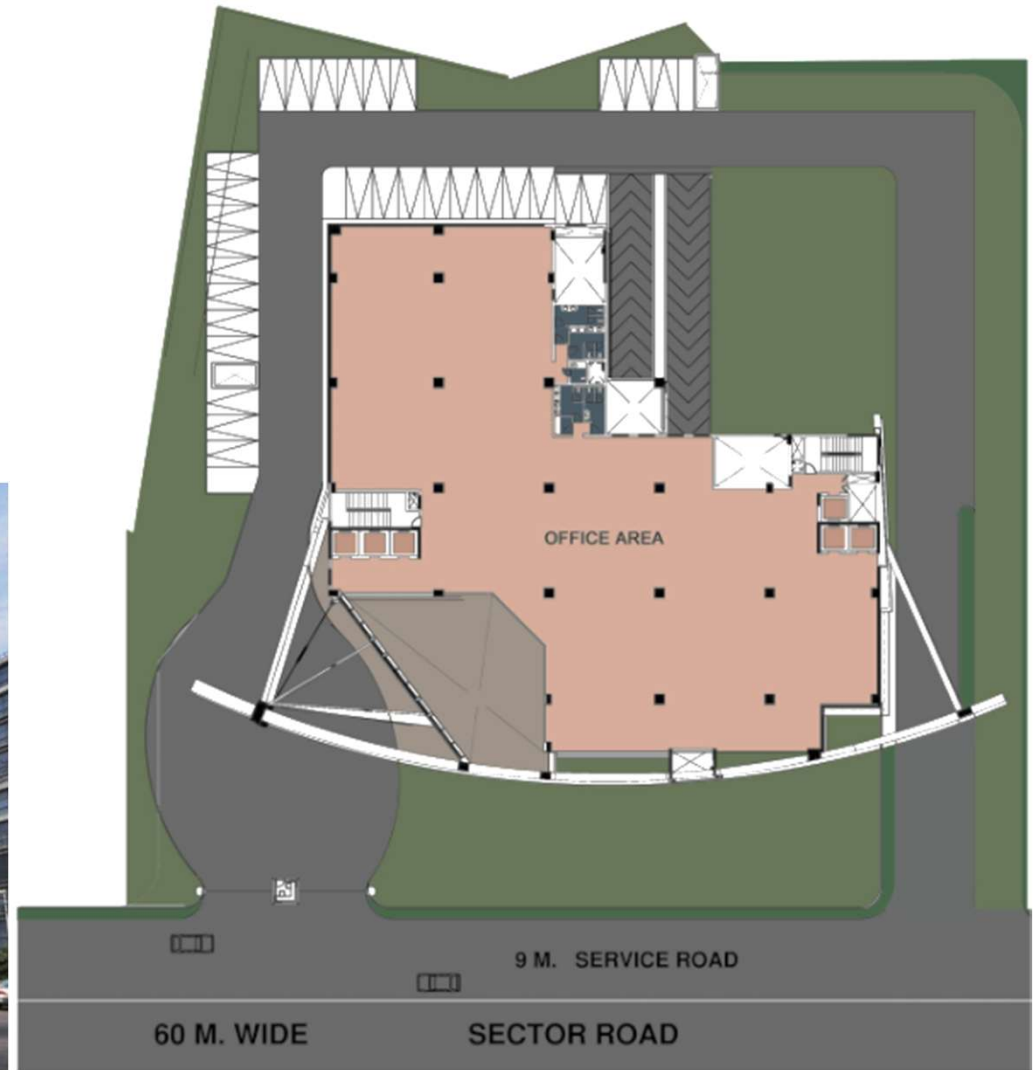

Design Development



CYBER CEZ

- In cyber city, cyber sez is a futuristic IT park with state - of-the-art infrastructure built to meet international standards.
- This integrated ITSEZ complex will comprise of four buildings with 11 blocks.
- The modern and well-planned workspaces of building 14 lend a distinctive appeal to its aesthetically designed wonder with over 5 acres of total area.
- Equipped with MERV-14 filters and LEED Platinum USGBC certifications.

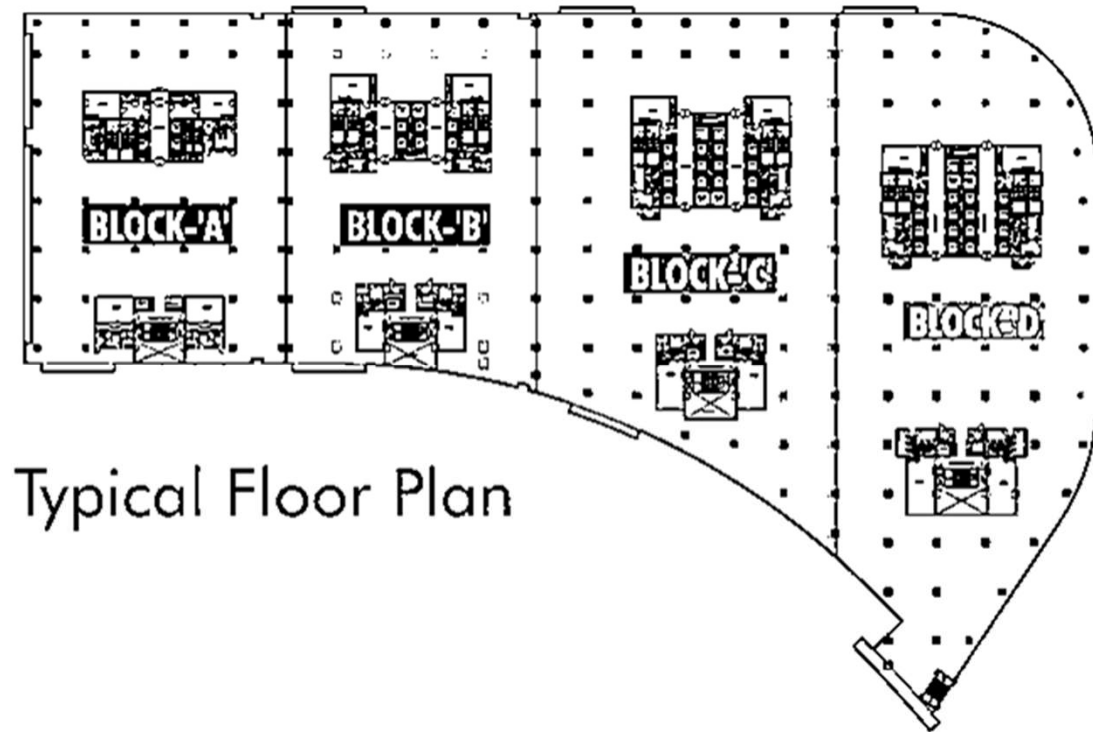

Typical Floor Plan

9A & 9B:-

- The elegant and cutting-edge twin tower edifice showcases some of the trendiest structures in contemporary architecture in the world.
- From the stunning foyer to the state-of-the-art amenities and ambience, you'll find a sophisticated design language greeting you at every place.
- The complex comprises two towers, 9a and 9b, both mirror images of each other, with 16 floors, independent lobbies and separate elevators.

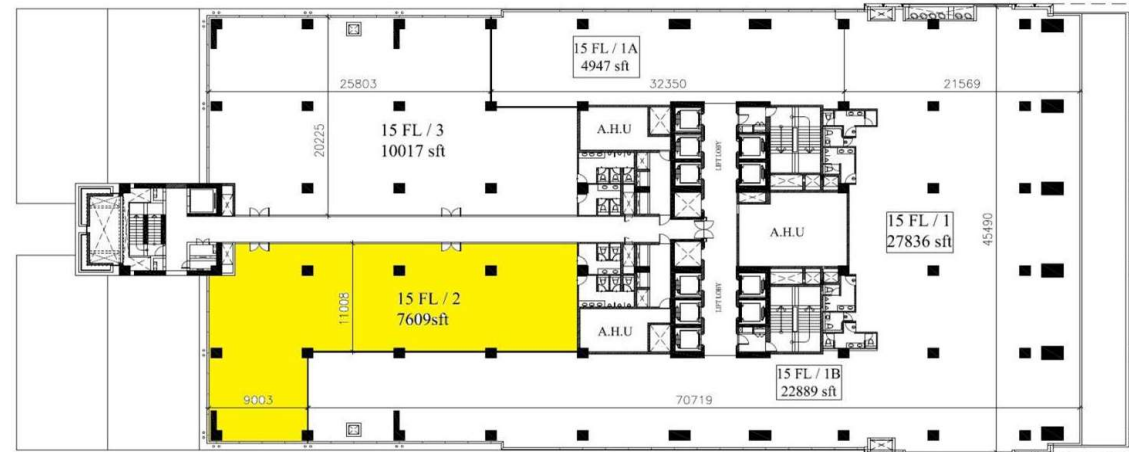

Design Development



SUSTAINABILITY INITIATIVES :

WATER MANAGEMENT

- Zero water discharge — 100% greywater treatment & reuse
- Sewage Treatment Plant (STP): treats millions of litres daily
- Recycled water used for landscaping, cleaning & flushing
- Multiple rainwater harvesting pits across 125 acres
- Groundwater recharge — measurable rise in local water table
- LEED Zero Water certified by USGBC

WASTE MANAGEMENT

- LEED Zero Waste certification (Buildings 7A, 7B, 9A, 9B)
- E-waste segregation systems installed across campus
- Advanced dry & wet waste processing
- Zero-landfill commitment — near-total diversion of waste
- Composting of organic waste from F&B operations at Cyber Hub
- Regular ESG audits aligned with GRESB Green Star 4-Star standards

ENERGY & POWER

- GIS (Gas Insulated Switchgear) captive power plant — co-generation tech
- Solar power modules installed on rooftops across campus
- High-efficiency chillers, pumps & elevators — continuous monitoring
- 5-Star BEE (Bureau of Energy Efficiency) certified buildings
- MERV-14 air filtration in all buildings — near-hospital indoor air quality
- Cutting-edge light fixtures to prevent light pollution

MOBILITY & GREEN SPACES

- EV charging stations at multiple locations across campus
- Dedicated last-mile metro rail connectivity (6 Rapid Metro stations)
- Multiple bus stops and e-rickshaw last-mile services
- Abundant green landscaping — stress-reducing micro-climate
- Pedestrian-friendly walkways & cycle paths
- GRESB Green Star & 4-Star rating for standing investment portfolio

SWOT ANALYSIS :

STRENGTHS

- World's first LEED Platinum City — unmatched sustainability credentials
- India's largest integrated IT business district (125 acres, 15 Mn sq ft)
- 94% office & 99% retail occupancy — near-full capacity
- AAA CRISIL credit rating — top-tier financial stability
- Dedicated Rapid Metro (6 stations) — premium transit access
- 21 British Safety Council Swords of Honour — global safety leader
- Tenant roster: 500+ companies incl. Google, IBM, Accenture, TCS, Barclays

OPPORTUNITIES

- Cyber City 2.0 expansion can absorb growing demand
- Delhi Metro Phase 4 extension to improve mass connectivity
- Global Capability Centre (GCC) boom in India — major target occupants
- Net-Zero Carbon certification pursuit adds premium positioning
- Rising ESG compliance requirements globally favour the campus
- Smart City Gurugram initiatives to further improve urban quality

WEAKNESSES

- Severe peak-hour traffic congestion on NH-48 and adjacent roads
- Limited affordable residential options within the immediate precinct
- High commercial rent — barriers for startups and SMEs
- Parking insufficiency reported by tenants and visitors
- Rapid Metro network limited in reach beyond Cyber City corridor
- Overdependence on private cars for last-mile beyond metro

THREATS

- Competition from Noida, Hyderabad, Bengaluru for large corporate leases
- Hybrid work models potentially reducing overall office demand
- Infrastructure strain as Gurugram's population & traffic grows
- Environmental concerns from continued urban densification
- Rising construction & operational costs squeezing yields
- Geopolitical uncertainty impacting MNC expansion decisions

MSRDC COMMERCIAL PARK PRESENTATION
BY VAO ARCHITECTS
PANVEL, MAHARASHTRA

Design Development



The Visionary Plaza

Blueprint for Modern Urban Integration



Proposed Conceptual Design For Commercial Complex at Arivali Panvel, Navi Mumbai

Concept



A tripartite framework governs the plaza's self-sustaining ecosystem

Sustainable Ecology

Anchored by a groundbreaking 30:70 built-to-green ratio.

Economic Vitality

Driven by stacked mixed-use commercial tiers and ground-level retail.

Community Flow

Engineered through a strictly pedestrian-centric core and perimeter transit routing.

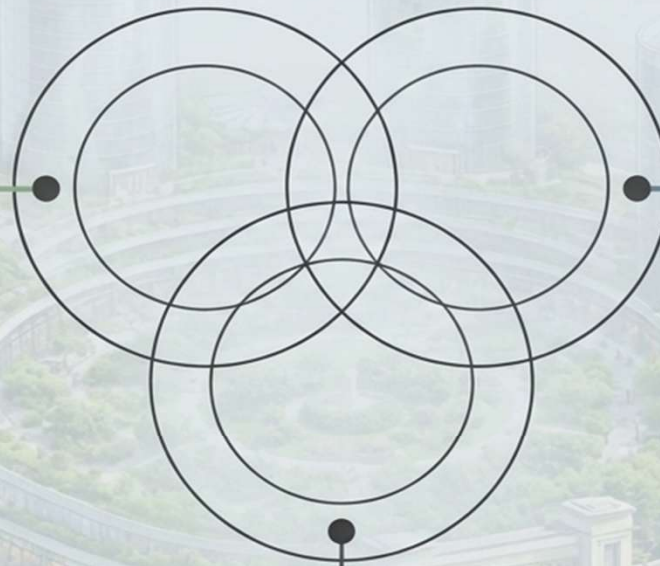

Proposed Conceptual Design For Commercial Complex at Arivali Panvel, Navi Mumbai

Concept

NotebookLM



PETAL-SHAPED COMMERCIAL COMPLEX DESIGN CONCEPT

CONCEPT

The masterplan is inspired by a blooming flower, where petal-shaped towers radiate from a vibrant public plaza, creating a dynamic commercial landmark that symbolizes growth, connectivity, and urban vitality.

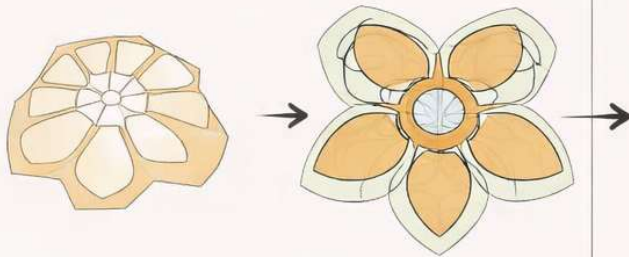

DESIGN EVOLUTION





List of design functions

1. Retail shops
2. Food court
3. Restaurants and cafés
4. Office spaces / co-working
5. Showrooms
6. event halls
7. Central plaza
8. Outdoor seating areas
9. Amphitheatre / event space
10. Exhibition area
11. Kids play zone
12. Gaming Zone
13. Fitness / wellness center
14. Reception / information lobby
15. Public toilets
16. ATM / banking kiosk
17. Customer service desk
18. Security room
19. First-aid / clinic room
20. Service corridors
21. Loading / unloading bays
22. Storage rooms
23. Maintenance rooms
24. Housekeeping rooms
25. Staff rooms / pantry
26. Electrical room
27. HVAC / mechanical rooms
28. Fire control room
29. Waste collection / disposal area
30. Main entrance drop-off
31. Basement / surface parking
32. Valet parking
33. Service entry
34. Pedestrian pathways
35. Vertical circulation cores
36. Escalators and lifts
37. Emergency exits
38. Green buffer zones
39. Water features
40. Courtyard spaces
41. Roof gardens / terrace cafés
42. Shaded walkways
43. Plaza seating with landscaping

Proposed Conceptual Design For Commercial Complex at Arivali Panvel, Navi Mumbai



Master Layout

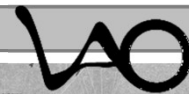

ARCHITECTURAL CONCEPT & FORM DEVELOPMENT: THE U-PLAZA COMPLEX

SITE & MASTER PLAN ANALYSIS
(Derived from <IMAGE>)

01. SITE ANALYSIS & RESPONSE

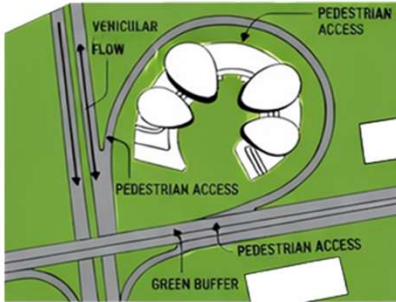

STEP 1: DEFINE ANCHOR POINTS

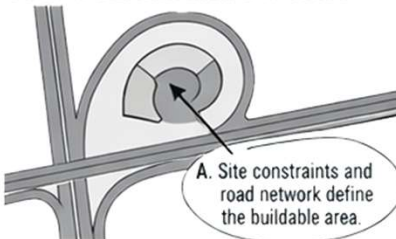

STEP 2: FORMAL RESPONSE

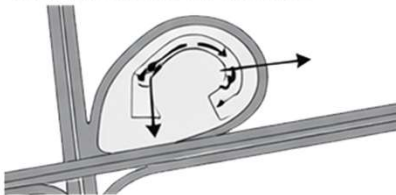

SITE PLAN & BASEMENT INTEGRATION
(Derived from <IMAGE-1>)

02. MASTER PLAN FORMULATION

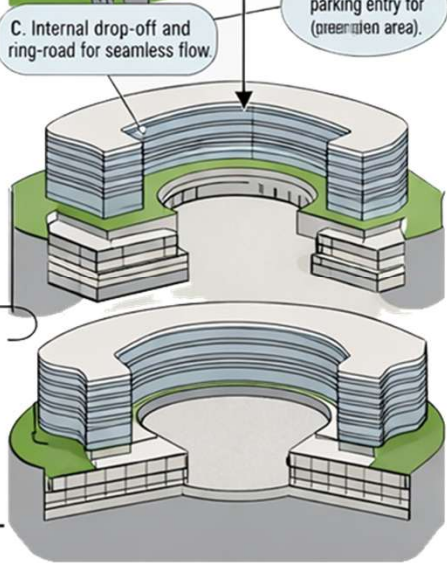
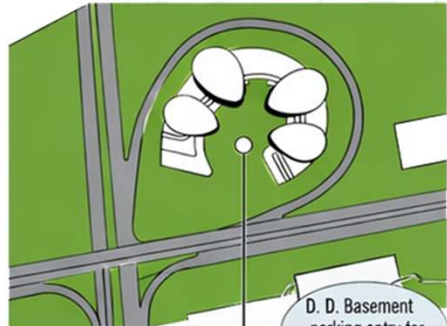

CONCEPT DEVELOPMENT VOLUMETRIC FORM

03. CASCADING VOLUMES THE CENTRAL PLAZA

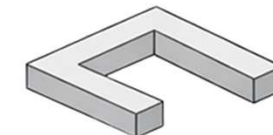

E. Four iconic, elipsoidal-cylindrical towers of varying heights (two short, two tall) anchor the composition.

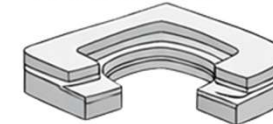

F. The U-bloche embraces a dynamic central plaza at its heart.

DETAILED FACADE & PROGRAMMING
(Detailed callouts from <IMAGE-1>)

04. REFINED GEOMETRY & PROGRAM MIX



Proposed Conceptual Design For Commercial Complex at Arivali Panvel, Navi Mumbai

Concept Development 

Visionary Plaza: The Blueprint for Modern Urban Integration

Visionary Plaza is a high-density urban development project designed to balance modern glass architecture with extensive green spaces. It utilizes a “pedestrian-centric” core and multi-tiered mixed-use spaces to create a sustainable, connected community environment.

Architectural Innovation & Layout



Four Cylindrical Glass Towers: Modern glass-walled clusters provide residents with 360-degree views.



Horseshoe Footprint Layout: The U-shaped layout maximizes natural light and protects the interior.



Multi-Tiered Mixed-Use Spaces: Lower levels host social hubs, restaurants, and retail spaces.



Sustainability & Connectivity

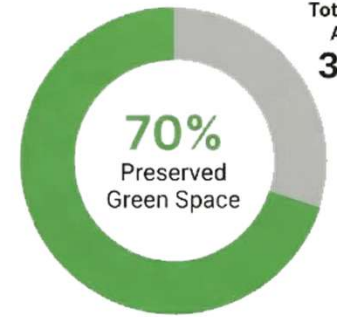

Car-Free Pedestrian Core: An interior designed specifically for foot traffic and accessibility.



Integrated Green Terraces: Rooftop gardens provide natural cooling and sustainable insulation.

Proposed Conceptual Design For Commercial Complex at Arivali Panvel, Navi Mumbai

Concept Development

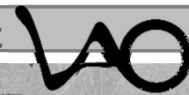



Proposed Conceptual Design For Commercial Complex at Arivali Panvel, Navi Mumbai

Conceptual Views





Proposed Conceptual Design For Commercial Complex at Arivali Panvel, Navi Mumbai

Conceptual Views





Proposed Conceptual Design For Commercial Complex at Arivali Panvel, Navi Mumbai

**ABOUT THE LOCATION:
VANGANI, MAHARASHTRA**





WELLWISHER GROUP
Elevating Life.. in Style

Why Vangani Is the Next Real Estate Hotspot Near Mumbai

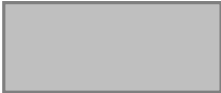
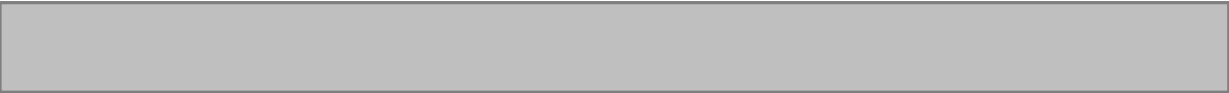

Design Development



VANGANI IT PARK

EASTERN MMR TECH CORRIDOR



AMBERNATH MIDC



DATA CENTRE HUB



INT'L AIRPORT (UPCOMING)



MUMBAI CITY

Build it as a district — not just an office park.

Design Development



REGION IS ALREADY IN MOTION:

HINDUSTAN TIMES
Sep 2025

Green integrated data centre park planned in Ambernath district near Mumbai

₹30,000 Cr

REUTERS
Jan 2026

Lodha expands plan to a 2.5 GW park — Reuters calls it the largest of its kind in India

2.5 GW

NDTV
Mar 2026

Navi Mumbai airport scales to 46 domestic destinations in first summer schedule

46 routes

MMRDA / NEWS
2025–26

Metro connectivity deepens around Kalyan–Ambernath through Line 5 / proposed extensions

mobility

What these articles collectively mean

DIGITAL CAPITAL

Large-scale infrastructure is already choosing the belt

MOBILITY CAPITAL

Rail, metro and airport layers are converging

DISTRICT OPPORTUNITY

A new employment node can arrive before the market saturates

Design Development



WHY THIS NODE WORKS:

Central Railway station
inside a multi-city commuter belt

Ambernath industrial adjacency
+ data centre catalyst

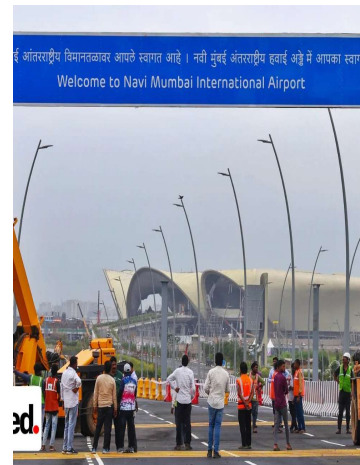
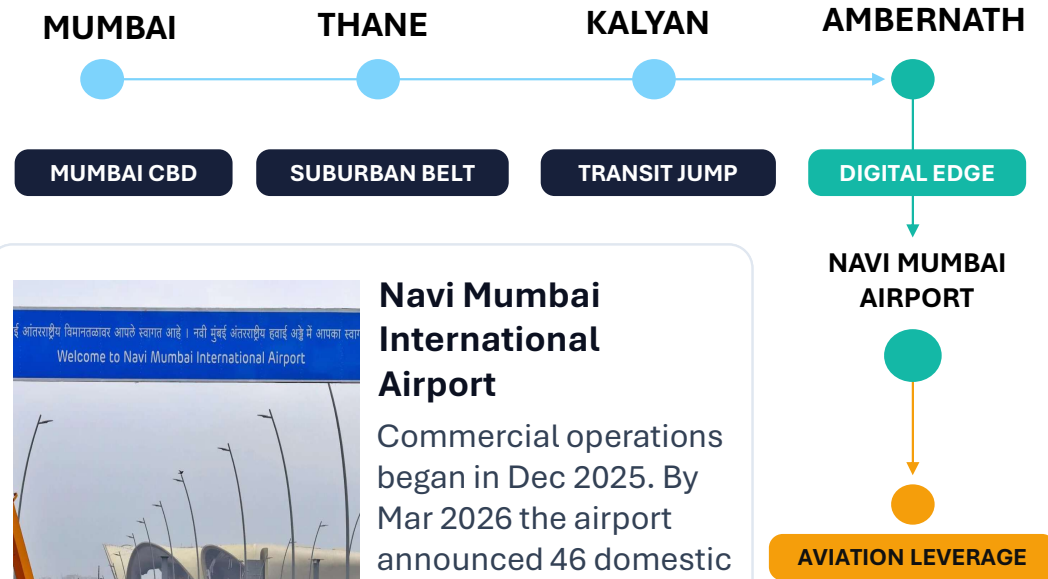

Navi Mumbai International Airport

Commercial operations began in Dec 2025. By Mar 2026 the airport announced 46 domestic destinations and 1,092 weekly movements.

airport pull



VGI

Vangani is already on the Central Railway network.

The near-term opportunity is not “inventing” access — it is converting an existing rail node into a higher-value employment district.

24.9 km

METRO LINE 5

15

STATIONS

50–75%

TIME CUT

Design Development



Vangani is not the next BKC.

That is exactly why it has value.

Position it as the eastern MMR tech district: rail-led, digitally adjacent, and buildable at district scale.

TRANSIT NODE

Already on the commuter rail map

DIGITAL EDGE

Adjacent to hyperscale digital infrastructure

PHASEABLE

Can start small and grow with demand

Build the first mixed-use tech district of the eastern commuter belt.

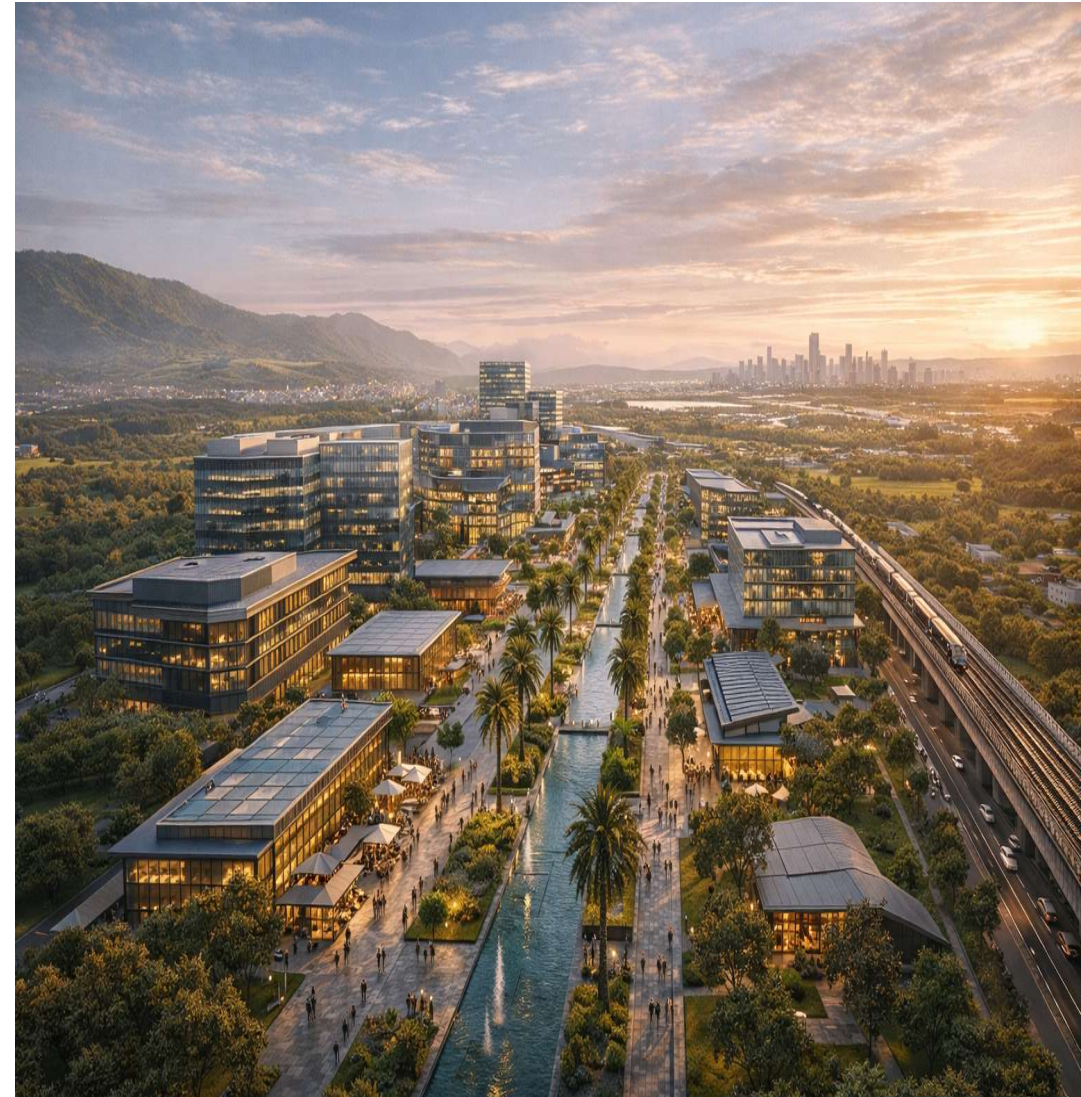

Design Development



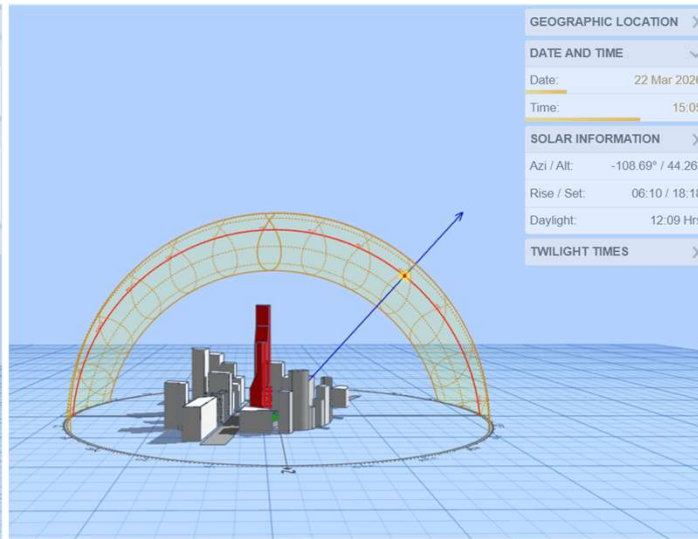
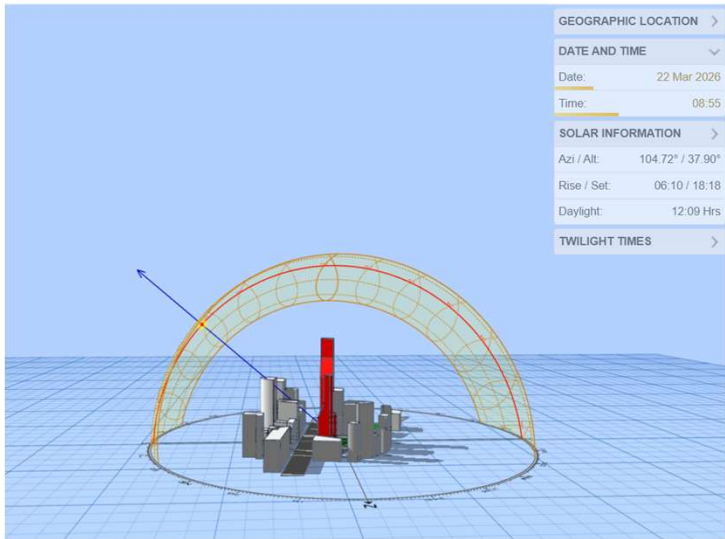

CLIMATE ANALYSIS:

Sunpath

The sun path here is aggressive; it stays high and tight in the summer with a significant shift toward the south in winter. Deep recessed balconies, vertical fins for solar shading, large floor-to-ceiling glazing protected by wide cantilevered slabs. Exposed board-formed concrete, warm terracotta jali screens, locally sourced basalt stone cladding, and darkened aluminium window frames

Vangani: Annual Wind Direction Frequency

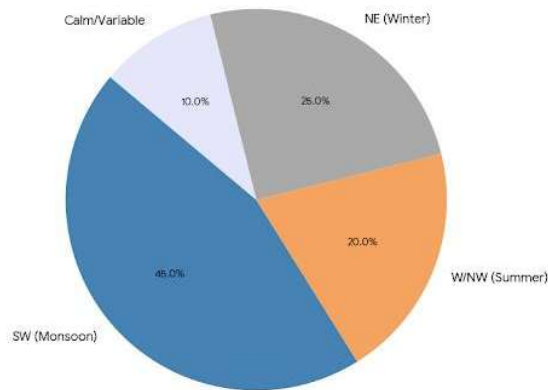

Wind/Monsoon

Vangani's wind profile is defined by a sharp seasonal shift.

The most critical factor for site planning is the South-West (SW) Monsoon, which brings high-velocity, moisture-laden gusts

Structures must be reinforced against the South-West for both wind pressure and water ingress

For energy efficiency, window placement on the North-East and North-West is optimal for cross-ventilation during the non-monsoon months without the risk of driving rain.

CONCEPTUAL PLANNING
THE IT PARK

Design Development



PROJECT VISION

**“A New Self-sustained Business ecosystem
& Lifestyle Destination
for Vangani”**

This project is envisioned as:

**A regional employment hub
A social and lifestyle destination
A future-ready commercial ecosystem**

**Not just an IT park
Not just a mall
But a hybrid commercial campus.**



Design Development



DEVELOPMENT STRATEGY

PHASE IT LIKE A DISTRICT:



PROPOSED PLOT FOR THE IT PARK:

NO	AREA STATEMENT	
01	AREA AS PER 7/12	37800.00.SQ.M
02	AREA AS PER DLR	37388.21.SQ.M
03	AREA AS PAR ON SITE	37651.82.SQ.M

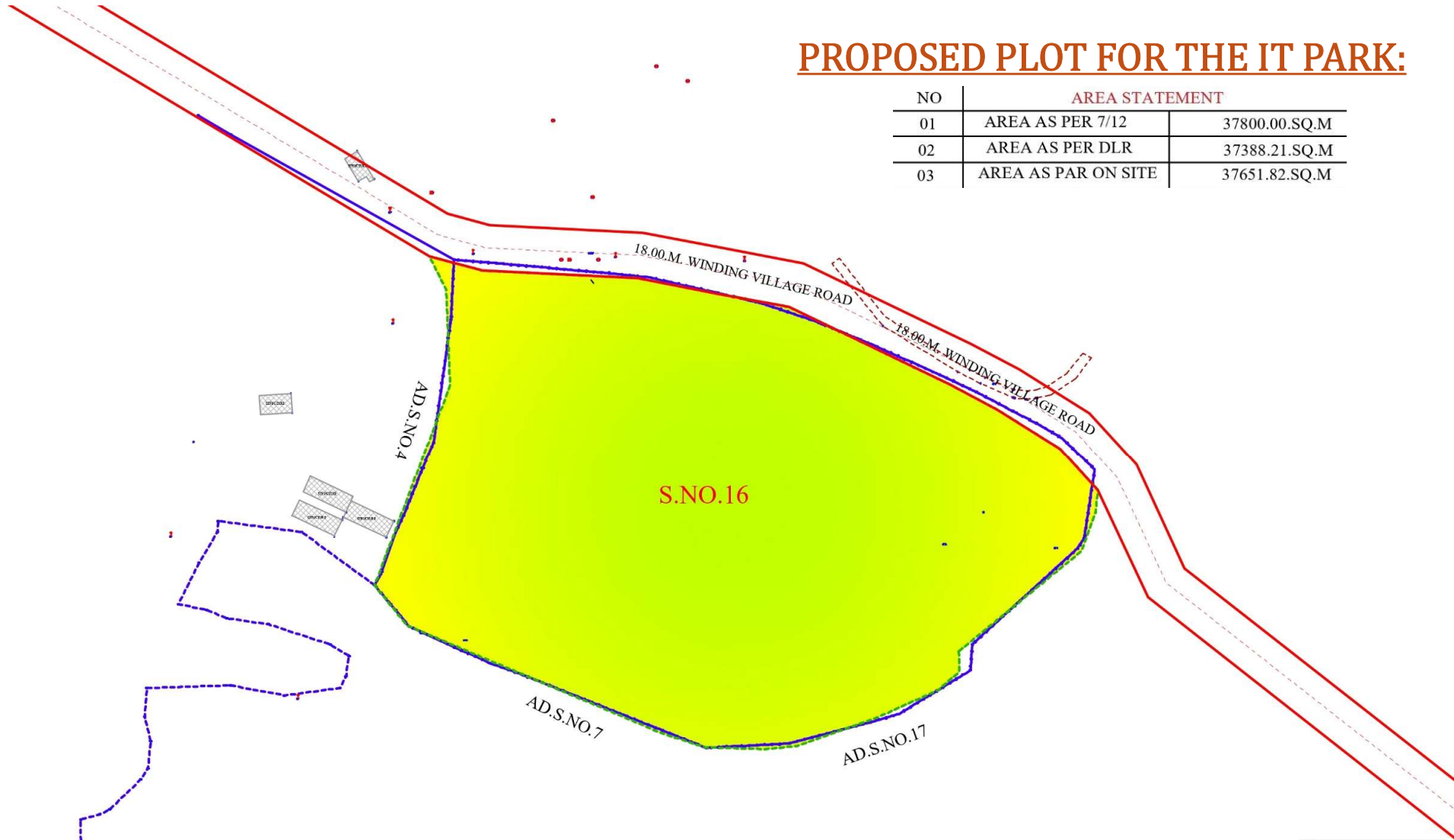

Design Development



ZONING OF THE PLOT:

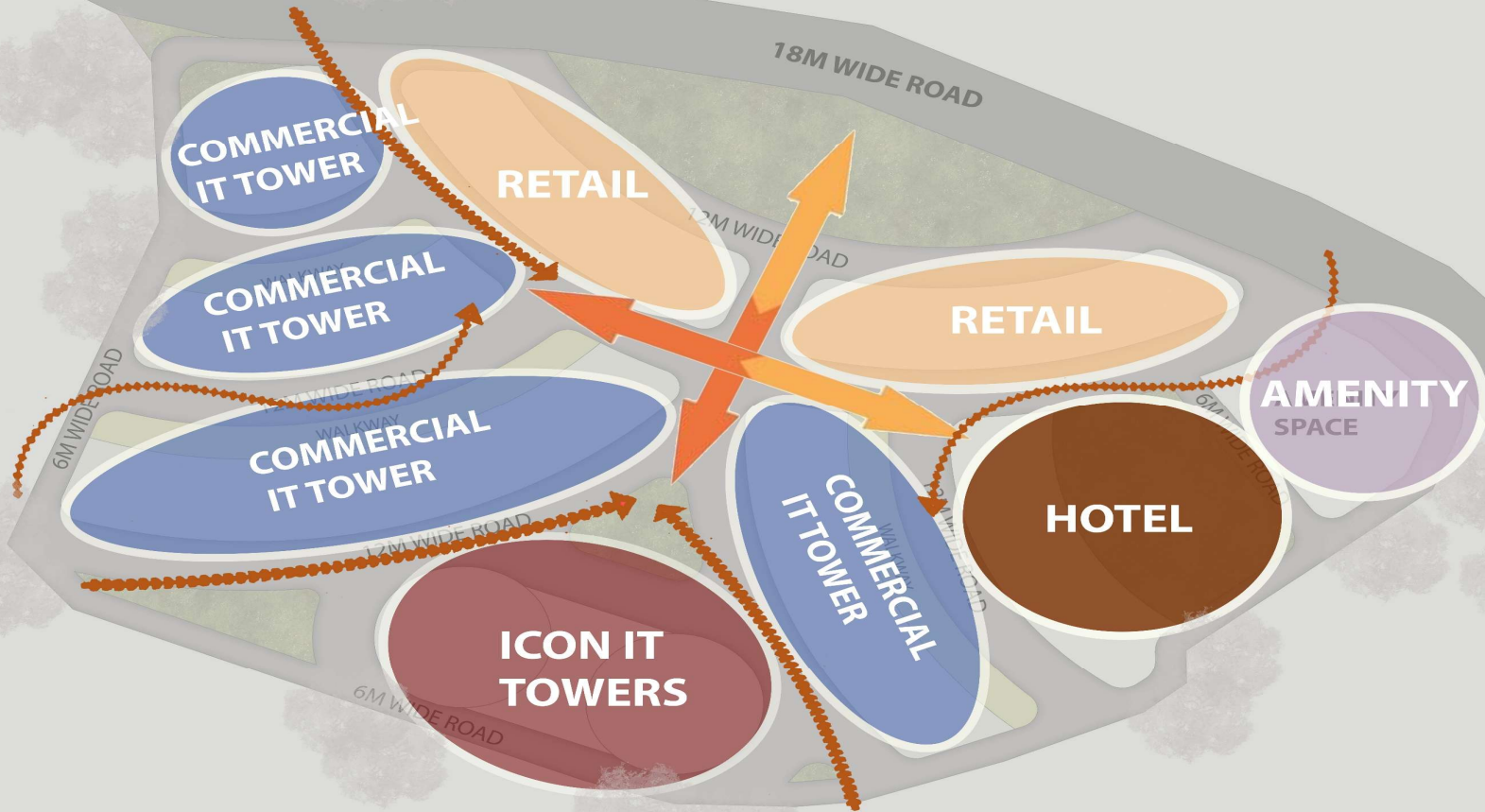

ZONING OF THE PLOT:

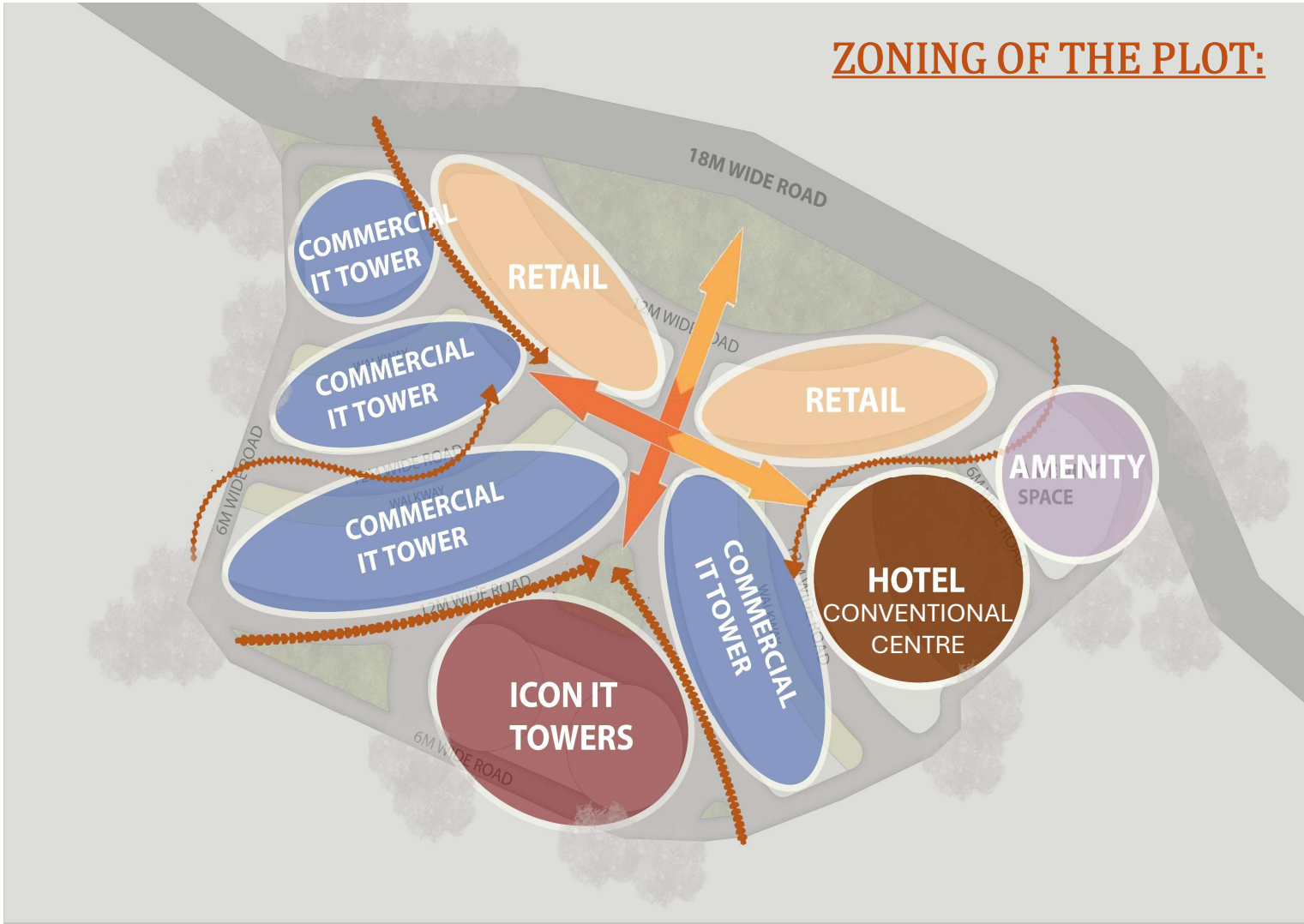

Front edge (18 m road)
Retail + entry plaza

Central zone
Public plaza + office lobbies +
Hotel/Convention Centre

Rear zone
Office towers

Side / rear edge
Service access

PROGRAM DISTRIBUTION

Component	Percentage
IT Offices	55-60%
Retail / Mall	15-20%
Hotel/Conventi onal Centre	8-10%
Amenities	5%
Circulation / shared areas	10-12%

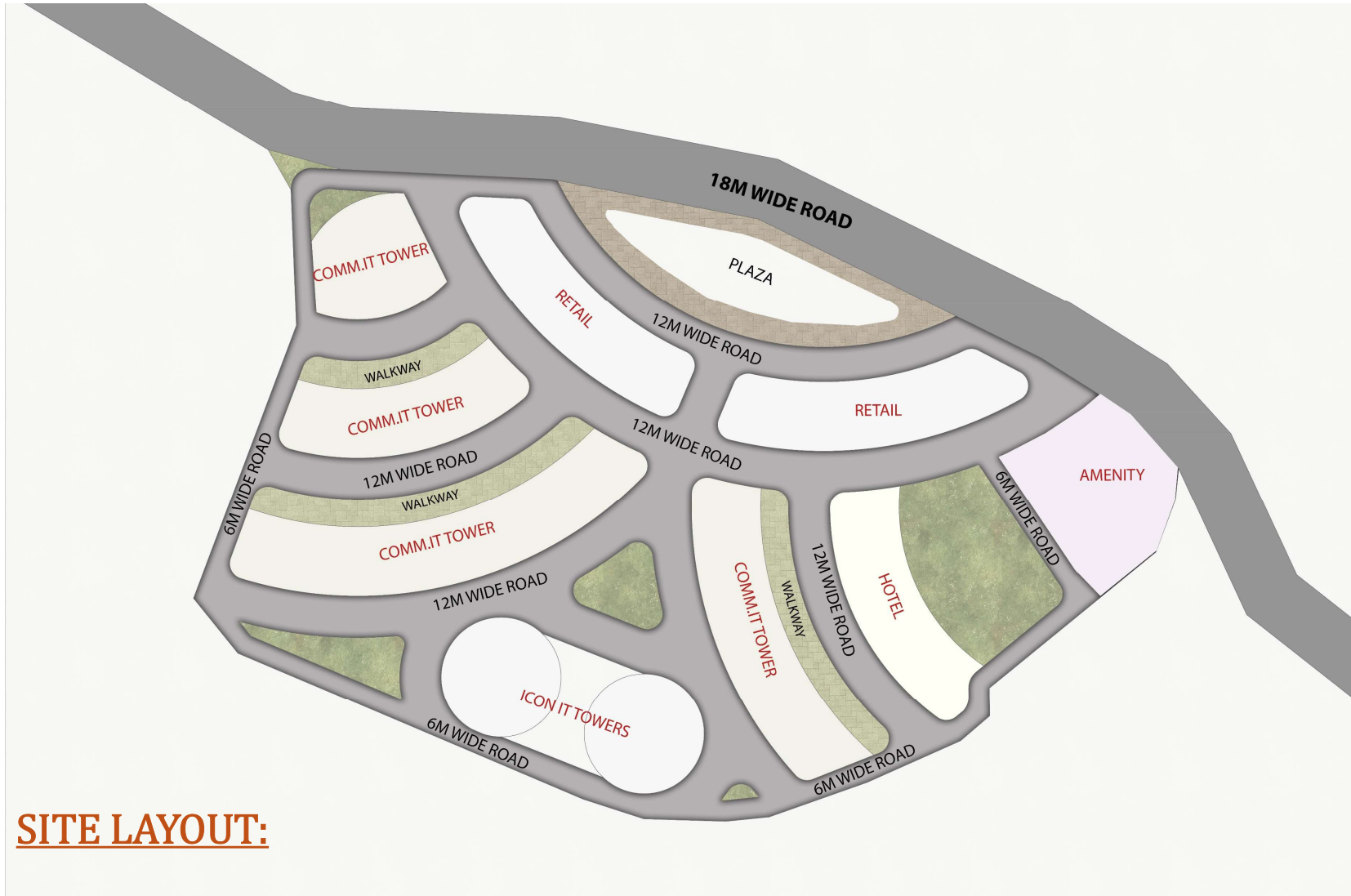

SITE LAYOUT:

Vehicular Circulation Strategy

Hierarchical Road Network

The site circulation is structured into a **three-tier hierarchy**:

Primary Access Road (Public Interface)

- Located along the **18 m wide abutting road**
- Functions as the **main entry spine**
 - visitor traffic
 - retail access
 - drop-offs

Designed as a **high-visibility, well-controlled entry zone**

Secondary Internal Roads (Campus Circulation)

- Distribute traffic within the site
 - office towers
 - retail podium
 - parking entries

Designed for **smooth internal movement without congestion**

Service Roads (Back-of-House Movement)

- Located along **rear / side edges of the site**
 - loading/unloading
 - waste management
 - utility access

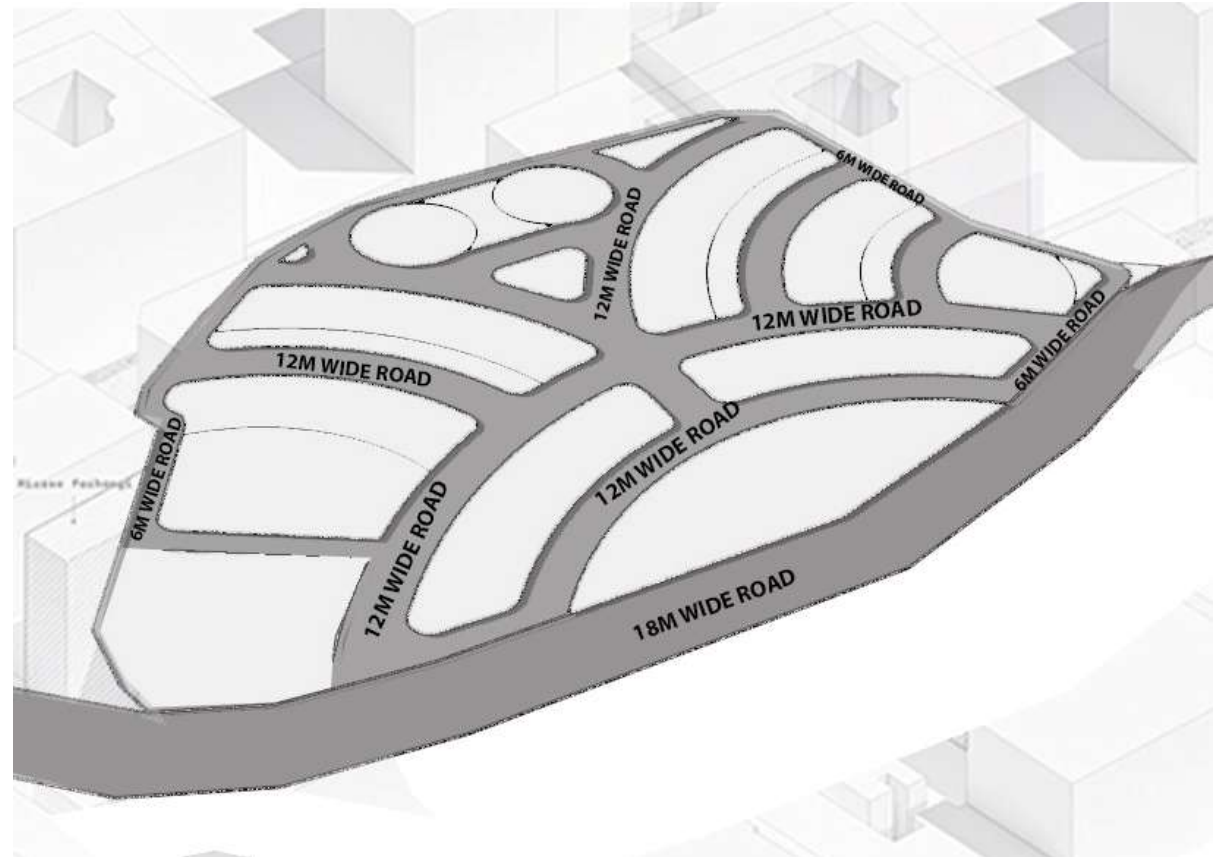

SITE LAYOUT CIRCULATION NETWORK

Design Development



Pedestrian & Walkability Strategy

Central Pedestrian Spine:

A **primary pedestrian axis** is introduced from the main entry into the site, forming the core of the development.

This spine connects:

- office towers
- retail zones
- public plaza
- amenities

Acts as the **social and functional heart of the campus**

Central Public Plaza:

- Located at the intersection of major movement paths
- Designed as:
 - gathering space
 - event zone

Encourages **interaction, activity, and vibrancy**

Shaded Walkways:

Given the climatic conditions:

Continuous shaded pathways are provided

Through:

- trees
- pergolas
- building overhangs

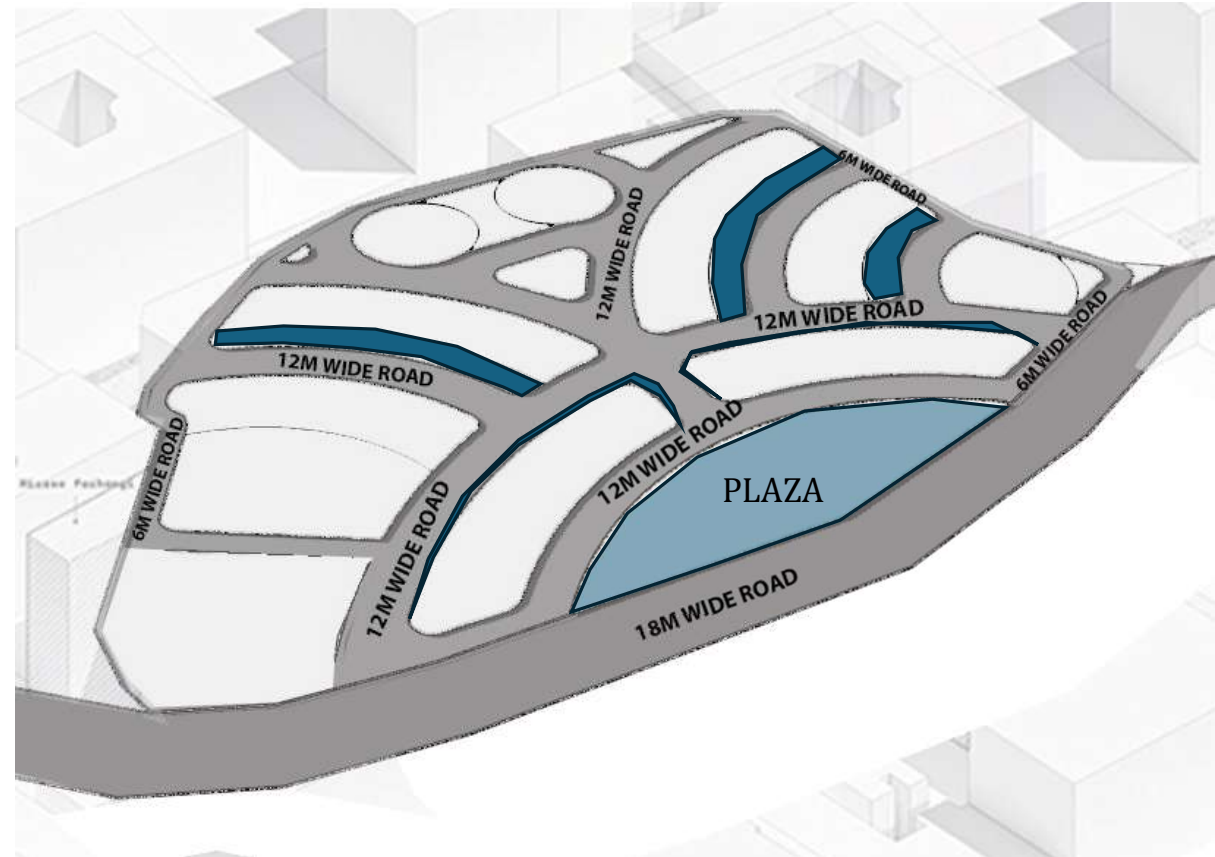

SITE LAYOUT PEDESTRIAN NETWORK

Design Development





SITE LAYOUT GREEN POCKETS

Design Development



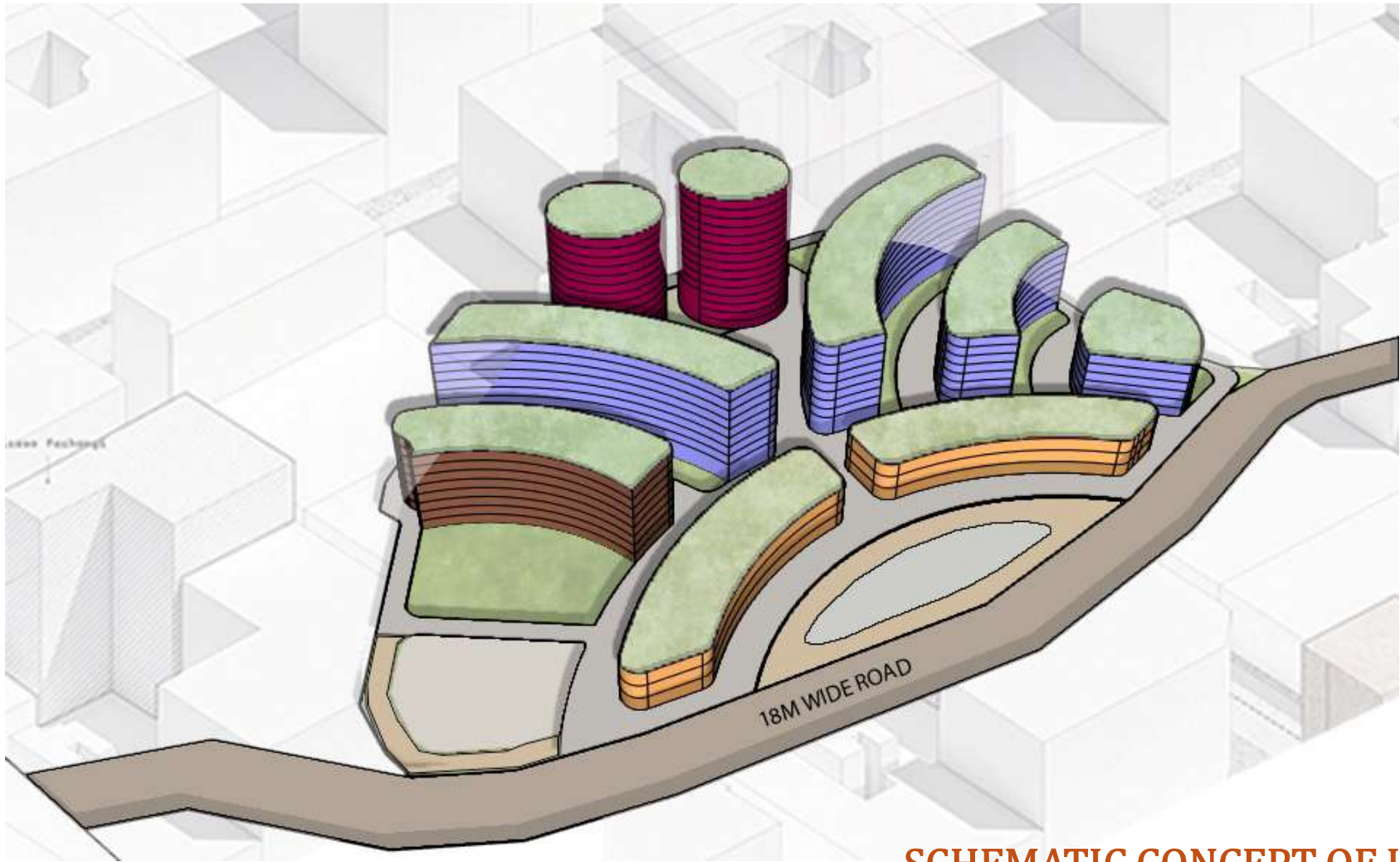

SCHEMATIC CONCEPT OF IT PARK

Design Development



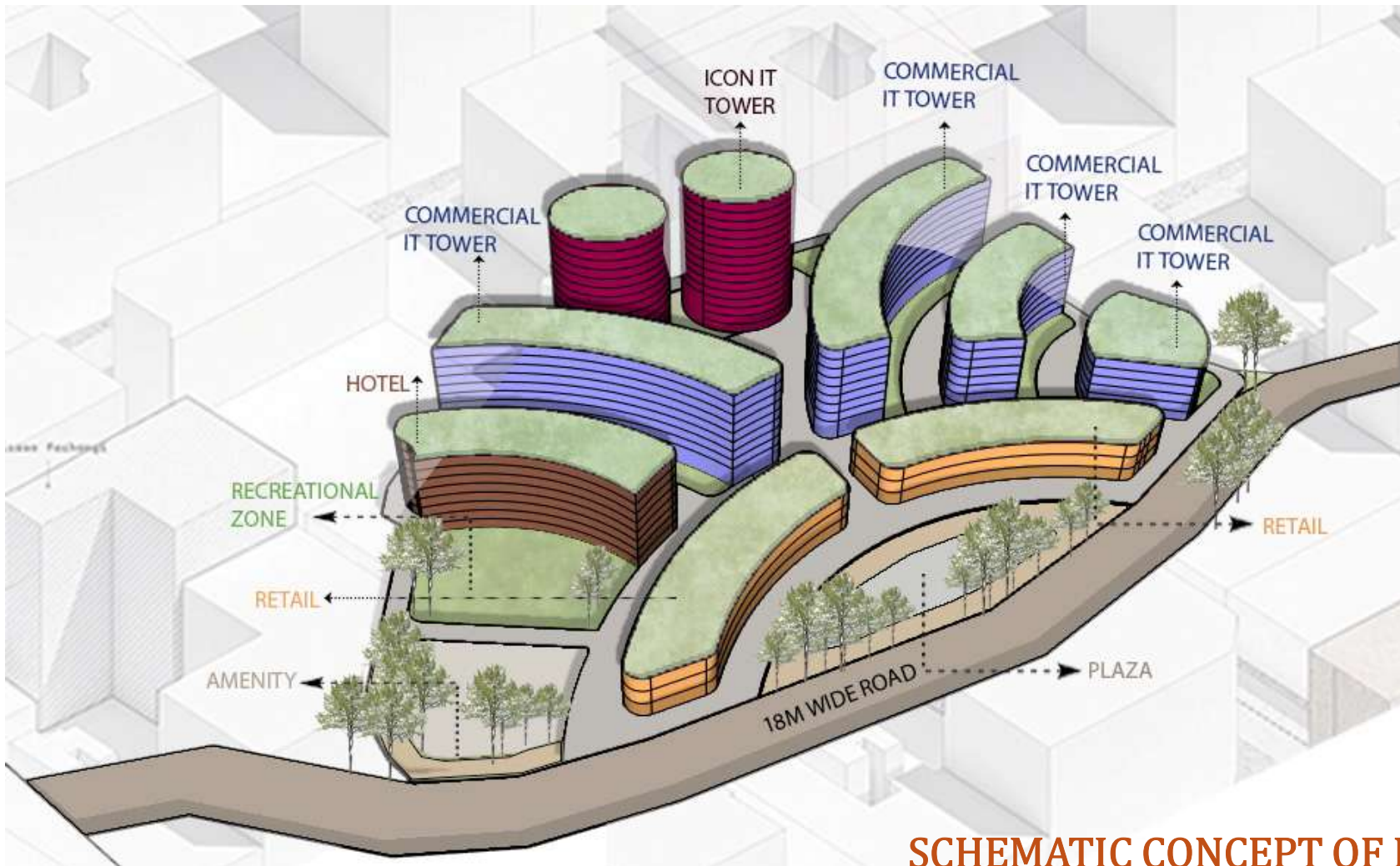

SCHEMATIC CONCEPT OF IT PARK

Design Development





RETAIL STREET + OPEN SPINE (IT PARK INTEGRATION)

- retail spine instead of only mall
- cafes opening into plaza
- shaded pedestrian street



Design Development





- Hybrid Plaza Strategy**
- ✓ Entry corporate plaza (formal)
 - ✓ Central social plaza (retail + F&B)
 - ✓ Landscape plaza (employee use)



Design Development





Hotel + Conventional Centre:

Shifting from:

IT Park to **Integrated Business Destination**

- No high-quality business hotels nearby
- Industrial + IT demand (MIDC + offices)
- Wedding / social event demand
- Corporate training + conferences



Design Development





Hotel + Conventional Centre:

Shifting from:

IT Park to **Integrated Business Destination**

- No high-quality business hotels nearby
- Industrial + IT demand (MIDC + offices)
- Wedding / social event demand
- Corporate training + conferences



Design Development





IT Commercial Buildings:

Towers arranged in **clusters (not isolated)**

Internal roads + landscape planned first

Dedicated zones for:

- office
- recreation
- infrastructure



Design Development



PROFORMA - I : AREA STATEMENT (AS PER 18M ROAD)		
PROPOSED IT PARK AT VANGANI		
	Stamps of Approval of Plans:	
	AREA STATEMENT	
1)	Area of plot (Minimum area of a, b, c to be considered)	37651.820
	(a) As per ownership document (7/12, CTS extract)	37800.000
	(b) as per DYSLR	
	(c) as per site	37651.820
2)	Deductions for	
	(a) Proposed D.P./ D.P. Road widening Area/Service Road / Highway widening	
	(i) Proposed D.P.	0.000
	(ii) Existing road widening	0.000
	(b) Any D.P. Reservation area	0.000
	(c) Area under existing road as per DYSLR	0.000
	(Total a+b+c)	
3)	Balance area of plot (1-2)	37651.820
4)	Amenity Space (if applicable)	
	(a) 5% Amenity Space Required	1882.591
	(b) Adjustment of 2(b), if any	-
	(c) Balance Proposed	
5)	Net Plot Area (3-4 (c))	35769.229
6)	Recreational Open space - (if applicable)	
	(a) Required	3576.92
	(b) Proposed -	576.00
7)	Internal Road area	
8)	Plotable area (if applicable)	
9)	Built up area with reference to IT Park - 3.5 as per 18 m wide Road	125192.302
10)	Addition of FSI on payment of premium	
	(a) Maximum permissible premium FSI - based on road width / TOD Zone (0.5)	
	(b) Proposed FSI on payment of premium.	
	(c) Proposed FSI on Against DP Road 2.0	
	(d) In situ Amenity FSI 2.0 after handover through construction	
	(e) Proposed FSI on TDR 0.65	
11)	Total entitlement of FSI in the proposal	
	(a) [9 + 10(b)] whichever is applicable	125192.302
	(b) Ancillary Area FSI upto 60% or 80% with payment of charges (11a X 60%)	100153.841
	(c) Total entitlement (a+b)	225346.143
12)	Maximum utilization limit of F.S.I. (building potential) Permissible as per Road width {(as per Regulation No. Regulation 7.8.1, 7.8.2 or 7.8.3)}	225346.143
13)	Total Built-up Area in proposal. (excluding area at Sr.No.17 b)	
	(a) Existing Built-up Area	0.000
	(b) Proposed Built-up Area	
	(c) Total (a+b)	0.000
14)	F.S.I. Consumed (13/12) (should not be more than serial No.14 above.)	0.000

THANK YOU



15, MITTAL TOWER OPP - VIDHAN BHAVAN, NARMAN POINT, MUMBAI - 400021